

GUGLIELMI®



Pura®



FIRB02506

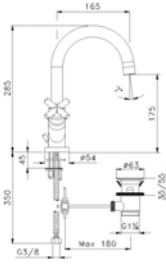

FIRB02516



Gruppo monoforo per lavabo, con bocca girevole, areatore anticalcare M24x1, comando scarico 1"¼, flex di alimentazione 3/8".

Single hole washbasin mixer, swivel spout, lime resistant areator M24x1, 1"¼ pop-up waste, connection flexible hose 3/8".

Mélangeur lavabo monotrou, bec mobile, aérateur anticalcaire M24x1, vidage 1"¼, flex d'alimentation 3/8".

Waschtisch-Armatur, Schwenkauslauf, Anti-Kalk Perlator M24x1, Ablaufgarnitur 1"¼, flexibler Anschluss Schlauch 3/8".

Monoblock para lavabo, caño giratorio, aireador anticalcáreo M24x1, desagüe 1"¼, flex. de alimentación 3/8".

FBPU58503 05 276,00



FIRB02506

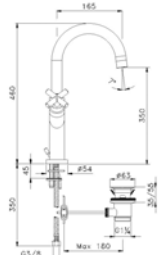

FIRB02516



Gruppo monoforo per lavabo catino, con bocca girevole, areatore anticalcare M24x1, comando scarico 1"¼, flex di alimentazione 3/8".

Single hole bowl mixer, swivel spout, lime resistant areator M24x1, 1"¼ pop-up waste, connection flexible hose 3/8".

Mélangeur lavabo monotrou pour bassin, bec mobile, aérateur anticalcaire M24x1, vidage 1"¼, flex d'alimentation 3/8".

Waschtisch-Armatur für Waschtischschüssel, Schwenkauslauf, Anti-Kalk Perlator M24x1, Ablaufgarnitur 1"¼, flexibler Anschluss Schlauch 3/8".

Monoblock para lavabo-cuenca, caño giratorio, aireador anticalcáreo M24x1, desagüe 1"¼, flex. de alimentación 3/8".

FBPU58505 05 338,00



FIRB02506

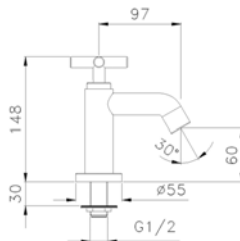

Rubinetto per lavabo solo acqua fredda o calda, areatore anticalcare M22x1, attacco ½".

Washbasin filler for hot or cold water only, lime resistant areator M22x1, ½" connection.

Robinet pour lavabo ½", seulement pour eau froide ou chaude, aérateur anticalcaire M22x1, vidage 1"¼, flex d'alimentation 3/8".

Waschtisch-Armatur nur für Kalt- oder Warmwasser, Anti-Kalk Perlator M22x1, Anschluss ½".

Grifo para lavabo, sólo agua fría o caliente, aireador anticalcáreo M22x1, racor ½".

FBPU58516 05 138,00



FIRB02506

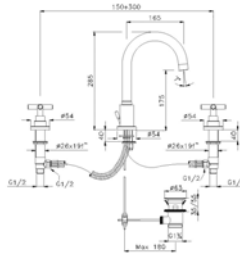

FIRB02516



Batteria a tre fori per lavabo, con bocca girevole, areatore anticalcare M24x1, comando scarico 1"¼.

Three-holes washbasin mixer, swivel spout, lime resistant areator M24x1, 1"¼ pop-up waste.

Mélangeur lavabo à trois trous, bec mobile, aérateur anticalcaire M24x1, vidage 1"¼.

3-Loch Waschtisch-Armatur, Schwenkauslauf, Anti-Kalk Perlator M24x1, Ablaufgarnitur 1"¼.

Bateria de tres agujeros para lavabo, caño giratorio, aireador anticalcáreo M24x1, desagüe 1"¼.

FBPU58500 05 346,00



FIRB02546

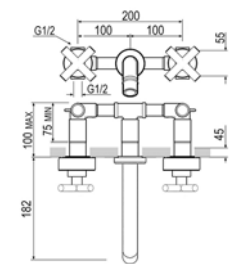

FIRB02547



Batteria a tre fori per lavabo a parete, attacco ½", bocca 150 mm, areatore anticalcare M22x1, senza scarico, completo di parte incasso.

Wall mounted three-holes washbasin mixer, ½" connection, 150 mm spout, lime resistant areator M22x1, without waste, complete of concealed part.

Mélangeur lavabo mural à trois trous, raccord ½", bec mm 150, aérateur anticalcaire M22x1, sans vidage, complet de partie encastrée.

3-Loch Waschtisch-Wandarmatur, Anschluss ½", Auslauf 150 mm, Anti-Kalk Perlator M22x1, ohne Ablaufgarnitur, komplett mit Grundkörper.

Bateria de tres agujeros para lavabo a pared, racor ½", caño mm 150, aireador anticalcáreo M22x1, sin desagüe, completo de parte empotrada.

FBPU58535 05 370,00



FIRB02506

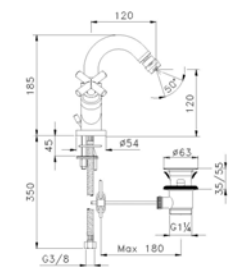

FIRB02516



Gruppo monoforo per bidet, con bocca girevole, getto orientabile, areatore anticalcare M24x1, comando scarico 1"¼, flex di alimentazione 3/8".

Single hole bidet mixer, swivel spout, adjustable jet, lime resistant areator M24x1, 1"¼ pop-up waste, connection flexible hose 3/8".

Mélangeur bidet monotrou, bec mobile, jet orientable, aérateur anticalcaire M24x1, vidage 1"¼, flex d'alimentation 3/8".

Bidet-Armatur, Schwenkauslauf, verstellbarer Strahl, Anti-Kalk Perlator M24x1, Ablaufgarnitur 1"¼, Anschluss Schlauch 3/8".

Monoblock para bidé, caño giratorio, flujo orientable, aireador anticalcáreo M24x1, desagüe 1"¼, flex. de alimentación 3/8".

FCPU58553 05 276,00



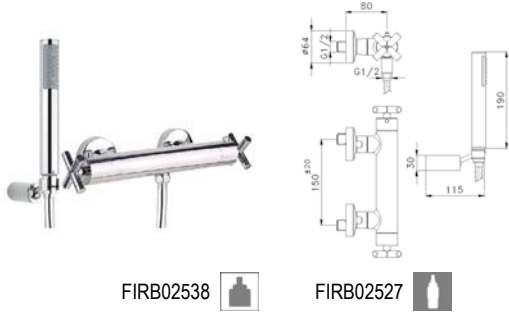

FIRB02538



FIRB02527



Miscelatore termostatico per doccia esterno, con fermo di sicurezza a 38° anticottatura, doccia anticalcare monogetto, supporto orientabile, flessibile 150 cm.

Thermostatic wall mounted shower mixer, anti-scald safety lock at 38°, lime resistant single-jet handshower, adjustable bracket, 150 cm flexible shower hose.

Mitigeur thermostatique pour douche extérieur avec arrêt de sécurité à 38° antibûlure, douchette anticalcaire monojet, support orientable, flexible cm 150.

Brausen-Thermostatmischer Aufputz, Sicherheitssperre 38° Anti-Verbrûhung, Anti-Kalk 1-Strahl Handbrause, verstellbarer Brausehalter, Flexschlauch 150 cm.

Mezclador termostático exterior para ducha, seguro 38° antiquemadura, ducha anticalcarea monochorro, soporte orientable, flex. cm 150.

FFTH47530 05 380,00



FIRB02538



FIRB02527



Miscelatore termostatico per doccia esterno, con fermo di sicurezza 38° anticottatura, saliscendi regolabile completo di doccia anticalcare 2 getti, supporto orientabile, flessibile 150 cm.

Thermostatic wall mounted shower mixer, anti-scald safety lock at 38°, adjustable sliding rail complete of lime resistant double-jets handshower, adjustable bracket, 150 cm flexible shower hose.

Mitigeur thermostatique douche extérieur, arrête de sécurité à 38° antibûlure, barre murale réglable, douchette anticalcaire 2 jets, support orientable, flexible 150 cm.

Brausen-Thermostatmischer Aufputz, Sicherheitssperre 38° Anti-Verbrûhung, verstellbare Brausestange komplett mit Anti-Kalk 2-Strahl Handbrause, verstellbarer Brausehalter, Flexschlauch 150 cm.

Mezclador termostático exterior para ducha, seguro 38° antiquemadura, barra de ducha regulable completa de ducha anticalcarea 2 chorros, soporte orientable, flex. cm 150.

FFTH47531 05 470,00



FIRB02538



FIRB02526



Miscelatore termostatico per doccia esterno, con fermo di sicurezza a 38° anticottatura, limitatore di portata risparmio acqua ed energia 50%, attacco doccia 1/2".

Thermostatic wall mounted shower mixer, anti-scald safety lock at 38°, flow control button (50% water and energy saving), 1/2" shower outlet.

Mitigeur thermostatique pour douche extérieur avec arrêt de sécurité à 38° antibûlure, douchette anticalcaire monojet, limiteur de débit épargne d'eau et énergie 50%, raccord douche 1/2".

Brausen-Thermostatmischer Aufputz, Sicherheitssperre 38° Anti-Verbrûhung, Durchflussbegrenzer für Wasser- und Energieeinsparung 50 %, Schlauchanschluss 1/2".

Mezclador termostático exterior para ducha, seguro 38° antiquemadura, limitador de caudal ahorro de agua y energia 50%, racor 1/2".

FFTH47532 05 300,00

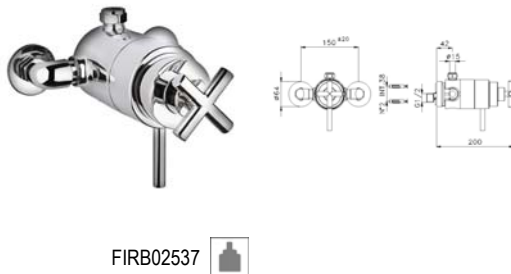

FIRB02537



Miscelatore termostatico coassiale per doccia esterno, grande portata di acqua, con fermo di sicurezza a 38° anticottatura, attacco doccia 1/2".

Coaxial thermostatic shower mixer, high flow rate, anti-scald safety lock at 38°C, 1/2" shower outlet.

Mitigeur thermostatique coaxial pour douche extérieur, grande débit d'eau, arrêt de sécurité à 38° antibûlure, raccord douche 1/2".

Koaxialer Brausen-Thermostatmischer Aufputz, hohe Durchflussmenge, Sicherheitssperre 38° Anti-Verbrûhung, Schlauchanschluss 1/2".

Mezclador termostático coaxial exterior para ducha, grande caudal, seguro 38° antiquemadura, racor 1/2".

FFCX43580 05 378,00



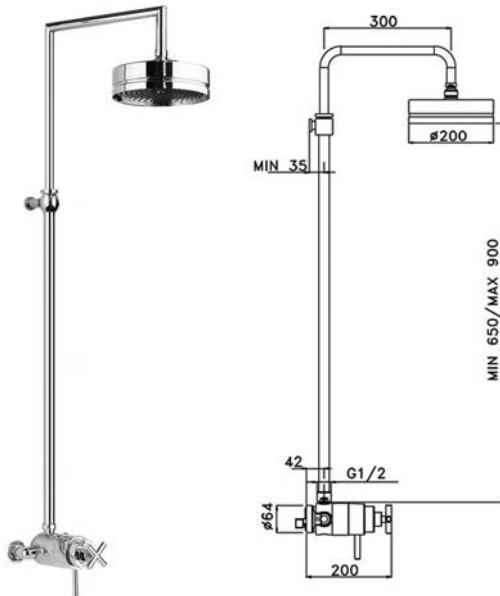

FIRB02537

Miscelatore termostatico coassiale per doccia esterno, grande portata di acqua, con fermo di sicurezza a 38° anticottatura, colonna doccia, braccio estensibile, soffione snodato.

Coaxial thermostatic shower mixer, high flow rate, anti-scald safety lock at 38°C, extendable shower column, adjustable showerhead.

Mitigeur thermostatique coaxial pour douche extérieure avec arrêt de sécurité à 38° antibrûlure, grande débit d'eau, colonne de douche, pomme de douche orientable et bras extensible.

Koaxialer Brausen-Thermostatmischer Aufputz, hohe Durchflussmenge, Sicherheitssperre 38° Anti-Verbrühung, Brausestange, verlängerbarer Brausearm, verstellbare Kopfbrause.

Mezclador termostático coaxial exterior para ducha, grande caudal, seguro 38° antiquemadura, columna ducha, brazo extensible, rociador articulado.

FFCX43802 05 1.132,00

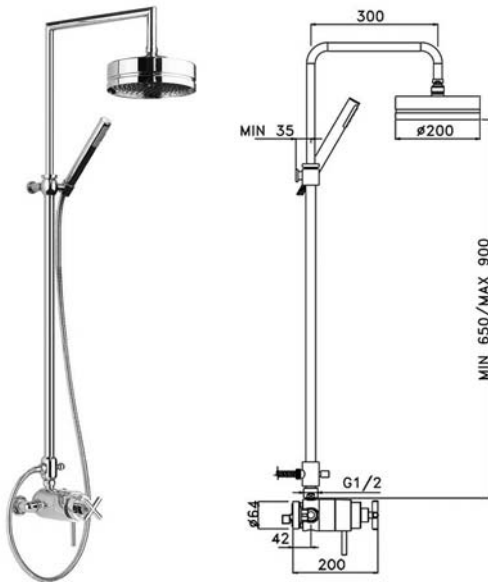

FIRB02537

Miscelatore termostatico coassiale per doccia esterno, grande portata di acqua, con fermo di sicurezza a 38° anticottatura, colonna doccia con deviatore, braccio estensibile, soffione snodato, completa di supporto orientabile, doccia anticalcare monogetto, flessibile 150 cm.

Coaxial thermostatic shower mixer, high flow rate, anti-scald safety lock at 38°C, extendable shower column with diverter, adjustable showerhead, complete of adjustable bracket, lime resistant single-jet handshower, 150 cm flexible shower hose.

Mitigeur douche thermostatique extérieure coaxial avec arrêt de sécurité à 38° antibrûlure, grande débit d'eau, colonne de douche avec inverseur, pomme de douche orientable et bras extensible, complet avec support orientable, douchette anticalcaire monojet, flexible cm 150.

Koaxialer Brausen-Thermostatmischer Aufputz, hohe Durchflussmenge, Sicherheitssperre 38° Anti-Verbrühung, Brausestange m. Umsteller, verlängerb. Brausearm, verstellb. Kopfbrause, kompl. m.verstellb. Brausehalter, Anti-Kalk 1-Strahl

Mezclador termostático coaxial exterior para ducha, grande caudal, seguro 38° antiquemadura, columna ducha con desviador, brazo extensible, rociador articulado, soporte orientable, ducha anticalcárea monochorro, flex. cm 150.

FFCX43803 05 1.255,00



FIRB02506

Gruppo per vasca esterno, deviatore manuale, areatore anticalcare M24x1, attacco doccia 1/2".

Wall mounted bath mixer, manual diverter, lime resistant areator M24x1, 1/2" shower outlet.

Mélangeur bain extérieur, inverseur manuel, aérateur anticalcaire M24x1, raccord douche 1/2".

Wannen-Armatur Aufputz, manueller Umsteller, Anti-Kalk Perlator M24x1, Schlauchanschluss 1/2".

Grupo exterior para baño/ducha, desviador manual, aireador anticalcáreo M24x1, racor 1/2".

FAPU58599 05 305,00



FIRB02506

Gruppo per vasca esterno, deviatore manuale, areatore anticalcare M24x1, doccia anticalcare monogetto, supporto fisso, flessibile 150 cm.

Wall mounted bath mixer, manual diverter, lime resistant areator M24x1, lime resistant single-jet handshower, fixed bracket, 150 cm flexible shower hose.

Mélangeur bain extérieur, inverseur manuel, aérateur anticalcaire M24x1, douchette anticalcaire monojet, support fix, flexible 150 cm.

Wannen-Armatur Aufputz, manueller Umsteller, Anti-Kalk Perlator M24x1, Anti-Kalk 1-Strahl Handbrause, fixer Brausehalter, Flexschlauch 150 cm.

Grupo exterior para baño/ducha, desviador manual, aireador anticalcáreo M24x1, ducha anticalcárea monochorro, soporte fijo, flex. cm 150.

FAPU58600 05 375,00



FIRB02502

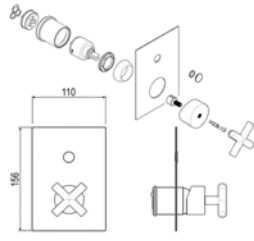

Parte esterna per monocomando da incasso per doccia, completa di miscelatore, da abbinare solo con JOLLY BOX.

External part for single lever shower mixer, complete with mixer, to be used with JOLLY BOX only.

Partie extérieure pour mitigeur douche à encastrer, complète avec mitigeur, compatible seulement avec JOLLY BOX.

Fertigset für Brausen-Einhebelmischer Unterputz, komplett mit Mischer, in Kombination nur mit JOLLY BOX.

Parte exterior para monomando empotrado para ducha, completa de mezclador, para combinar sólo con JOLLY BOX.

FIIN00779 05 174,00



FIRB02502

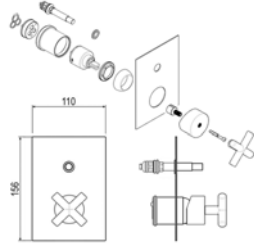

Parte esterna per monocomando da incasso per vasca doccia, completa di miscelatore e deviatore automatico, da abbinare solo con JOLLY BOX.

External part for single lever bath shower mixer, complete with mixer and automatic diverter, to be used with JOLLY BOX only.

Partie extérieure pour mitigeur bain/douche à encastrer, complète avec mitigeur et inverseur automatique, JOLLY BOX.

Fertigset für Wannen/Brausen-Einhebelmischer Unterputz, komplett mit Mischer und automatischem Umsteller, in Kombination nur mit JOLLY BOX.

Parte exterior para monomando empotrado para baño/ducha, completa de mezclador y desviador automático, para combinar sólo con JOLLY BOX.

FIIN00778 05 205,00



FIRB02579

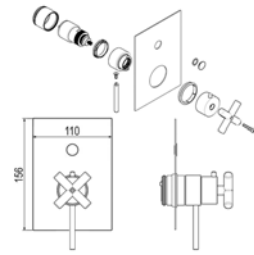

Parte esterna per termostatico da incasso per doccia, completa di miscelatore, da abbinare solo con JOLLY BOX.

External part for thermostatic shower mixer, complete of mixer, to be used with JOLLY BOX only.

Partie extérieure pour mitigeur thermostatique douche à encastrer, JOLLY BOX.

Fertigset für Brausen-Thermostatmischer Unterputz, komplett mit Mischer, in Kombination nur mit JOLLY BOX.

Parte exterior para termostático empotrado para ducha, completa de mezclador, para combinar sólo con JOLLY BOX.

FIIN00691 05 299,00



FIRB02579

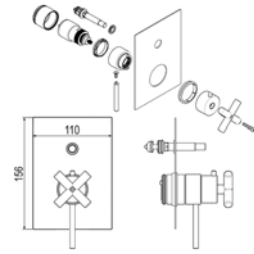

Parte esterna per termostatico da incasso per vasca doccia, completa di miscelatore e deviatore automatico, da abbinare solo con JOLLY BOX.

External part for thermostatic bath shower mixer, complete of mixer and automatic diverter, to be used with JOLLY BOX only.

Partie extérieure pour mitigeur thermostatique bain douche à encastrer, JOLLY BOX.

Fertigset für Wannen/Brausen-Thermostatmischer Unterputz, komplett mit Mischer und automatischem Umsteller, in Kombination nur mit JOLLY BOX.

Parte exterior para mezclador termostático empotrado para baño/ducha, completa de mezclador y desviador automático, para combinar sólo con JOLLY BOX.

FIIN00690 05 330,00



FIRB02538

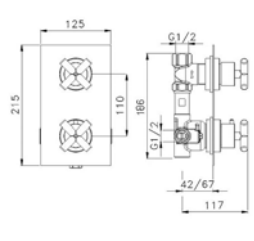

Miscelatore termostatico per doccia incasso, con fermo di sicurezza a 38° anticottatura, attacco 1/2", con rubinetto chiusura a 1 uscita, completo di parte incasso.

Thermostatic built-in shower mixer, anti-scald safety lock at 38°, 1/2" connection, shower stop cock (1 outlet), complete of concealed part.

Mitigeur thermostatique douche à encastrer avec arrêt de sécurité à 38° antibûlure, raccord 1/2", avec robinet d'arrêt à une sortie, complet de partie encastrée.

Brausen-Thermostatmischer Unterputz, Sicherheitssperre 38° Anti-Verbrühung, Anschluss 1/2", mit Absperrventil 1-Weg, komplett mit Grundkörper.

Mezclador termostático empotrado para ducha, seguro 38° antiquemadura, racor 1/2", cierre a una salida, completo de parte empotrada.

FDTH47570 05 347,00



10 A



FIRB02538

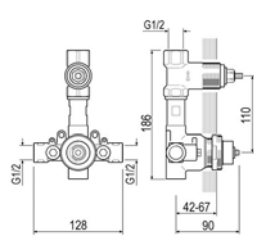

Corpo incasso miscelatore termostatico per doccia, attacco 1/2", con rubinetto chiusura a 1 uscita.

Concealed part for built-in thermostatic shower mixer, 1/2" connection, with shower stop cock (1 outlet).

Corps à encastrer pour mitigeur douche thermostatique, raccord 1/2", robinet d'arrêt à une sortie.

Grundkörper für Brausen-Thermostatmischer Unterputz, Anschluss 1/2", mit Absperrventil 1-Weg.

Cuerpo empotrado para mezclador termostático para ducha, racor 1/2", cierre a una salida.

FIIN00612 220,00



10 A

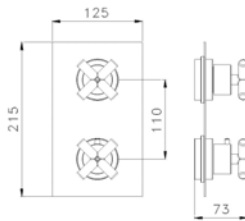

Parte esterna per miscelatore termostatico da incasso per doccia, con rubinetto chiusura a 1 uscita.

External part for thermostatic shower mixer, with shower stop cock (1 outlet).

Partie extérieure pour mitigeur thermostatique douche à encastrer, avec robinet d'arrêt à 1 sortie.

Fertigset für Brausen-Thermostatmischer Unterputz, mit Absperrventil 1-Weg.

Parte exterior para mezclador termostático empotrado para ducha, cierre a una salida.

FIIN00625 05 127,00

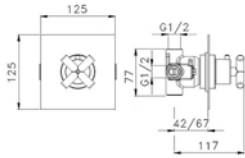

Miscelatore termostatico per doccia incasso, con fermo di sicurezza a 38° anticottatura, attacco 1/2", senza rubinetto chiusura, completo di parte incasso.

Thermostatic built-in shower mixer, anti-scald safety lock at 38°, 1/2" connection, without shower stop cock, complete of concealed part.

Mitigeur thermostatique douche à encastrer, avec arrêt de sécurité à 38° antibûlure, raccord 1/2", sans robinet d'arrêt, complet de partie encastrée.

Brausen-Thermostatmischer Unterputz, Sicherheitssperre 38° Anti-Verbrûhung, Anschluss 1/2", ohne Absperrventil, komplett mit Grundkörper.

Mezclador termostático empotrado para ducha, seguro 38° antiquemadura, racor 1/2", sin cierre, completo de parte empotrada.

FIRB02538

12 B

FDTH47574 05 292,00

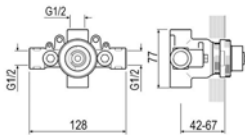

Corpo incasso miscelatore termostatico per doccia, attacco 1/2", senza rubinetto chiusura.

Concealed part for built-in thermostatic shower mixer, 1/2" connection, without shower stop cock.

Corps à encastrer pour mitigeur douche thermostatique, raccord 1/2", sans robinet d'arrêt.

Grundkörper für Brausen-Thermostatmischer Unterputz, Anschluss 1/2", ohne Absperrventil.

Cuerpo empotrado para mezclador termostático para ducha, racor 1/2", sin cierre.

FIRB02538

9 C

FIIN00637 164,00

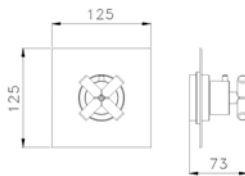

Parte esterna per miscelatore termostatico da incasso per doccia, senza rubinetto chiusura.

External part for thermostatic shower mixer, without shower stop cock.

Partie extérieure pour mitigeur thermostatique douche à encastrer, sans robinet d'arrêt.

Fertigset für Brausen-Thermostatmischer Unterputz, ohne Absperrventil.

Parte exterior para mezclador termostático empotrado para ducha, sin cierre.

FIIN00641 05 128,00

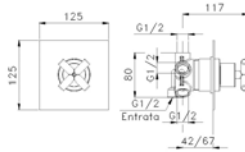

Rubinetto deviatore a 5 vie, attacco 1/2", senza chiusura, completo di parte incasso.

5-ways built-in diverter valve, 1/2" connection, without shower stop cock, complete of concealed part.

Robinet inverseur 5 voies, raccord 1/2" sans arrêt, complet de partie encastrée.

5-Wege Umsteller Unterputz, Anschluss 1/2", ohne Absperrventil, komplett mit Grundkörper.

Desviador empotrado 5 vías, racor 1/2", sin cierre, completo de parte empotrada.

FIRB02559

12 B

FDTH47952 05 256,00

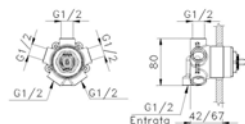

Corpo incasso rubinetto deviatore a 5 vie, attacco 1/2", senza chiusura.

Concealed part for 5-ways diverter valve, 1/2" connection, without shower stop cock.

Corps à encastrer pour robinet inverseur 5 voies, raccord 1/2", sans robinet d'arrêt.

Grundkörper für 5-Wege Umsteller Unterputz, Anschluss 1/2", ohne Absperrventil.

Cuerpo empotrado para desviador 5 vías, racor 1/2", sin cierre.

FIRB02559

20 C

FIIN03453 129,00

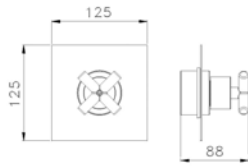

Parte esterna per rubinetto deviatore a 5 vie incasso, senza chiusura.

External part for 5-ways diverter valve, without shower stop cock.

Partie extérieure pour robinet inverseur 5 voies sans arrêt.

Fertigset für 5-Wege Umsteller Unterputz, ohne Absperrventil.

Parte exterior para desviador 5 vías, sin cierre.

FIIN00644 05 127,00

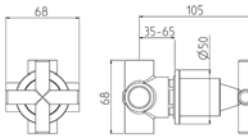

Rubinetto deviatore a 2 vie, attacco 1/2", con chiusura, completo di parte incasso.

2-ways built-in diverter valve, 1/2" connection, with shower stop cock, complete of concealed part.

Robinet inverseur à 2 voies, raccord 1/2", avec arrêt, complet de partie encastrée.

2-Wege Umsteller Unterputz, Anschluss 1/2", mit Absperrventil, komplett mit Grundkörper.

Desviador empotrado 2 vías, racor 1/2", con cierre, completo de parte empotrada.

FDPU58947 05 133,00

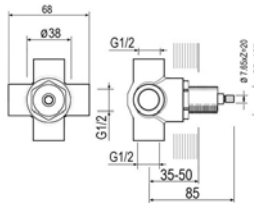

Corpo incasso per rubinetto deviatore a 2 vie, attacco 1/2", con chiusura.

Concealed part for 2-ways built-in diverter valve, 1/2" connection, with shower stop cock.

Corps à encastrer pour robinet inverseur à 2 voies, raccord 1/2", avec arrêt.

Grundkörper für 2-Wege Umsteller Unterputz, Anschluss 1/2", mit Absperrventil.

Cuerpo empotrado para desviador 2 vías, racor 1/2", con cierre.

FIIN03466 88,00

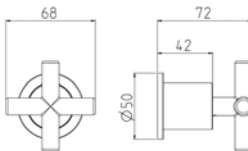

Parte esterna per rubinetto deviatore, con chiusura.

External part for diverter valve, with shower stop cock.

Partie extérieure pour robinet inverseur, avec arrêt.

Fertigset für Umsteller Unterputz, mit Absperrventil.

Parte exterior para desviador, con cierre.

FIIN01957 05 45,00

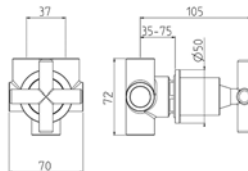

Rubinetto deviatore a 3 vie, attacco 1/2", con chiusura, completo di parte incasso.

3-ways built-in diverter valve, 1/2" connection, with shower stop cock, complete of concealed part.

Robinet inverseur à 3 voies, raccord 1/2", avec arrêt, complet de partie encastrée.

3-Wege Umsteller Unterputz, Anschluss 1/2", mit Absperrventil, komplett mit Grundkörper.

Desviador empotrado 3 vías, racor 1/2", con cierre, completo de parte empotrada.

FDPU58948 05 157,00

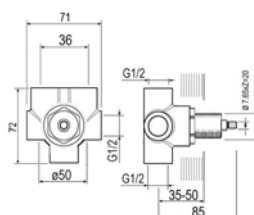

Corpo incasso per rubinetto deviatore a 3 vie, attacco 1/2", con chiusura.

Concealed part for 3-ways built-in diverter valve, 1/2" connection, with shower stop cock.

Corps à encastrer pour robinet inverseur à 3 voies, raccord 1/2", avec arrêt.

Grundkörper für 3-Wege Umsteller Unterputz, Anschluss 1/2", mit Absperrventil.

Cuerpo empotrado para desviador 3 vías, racor 1/2", con cierre.

FIIN03467 112,00



Parte esterna per rubinetto deviatore, con chiusura.

FIIN01957 05 45,00

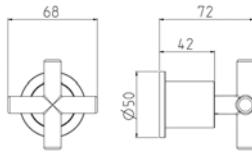

External part for diverter valve, with shower stop cock.

Partie extérieure pour robinet inverseur, avec arrêt.

Fertigset für Umsteller Unterputz, mit Absperventil.

Parte exterior para desviador, con cierre.



FIRB02506

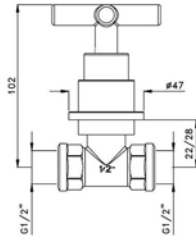

Rubinetto d'arresto da incasso, attacco 1/2", completo.

FDFU58950 05 98,00

Built-in stop cock, 1/2" connection, complete.

Robinet d'arrêt à encastrer, raccord 1/2", complet.

Absperventil Unterputz, Anschluss 1/2", komplett.

Llave de paso a empotrar, racor 1/2", completa.

20 N



FIRB02506

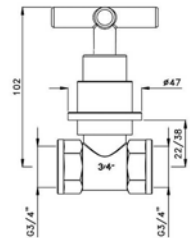

Rubinetto d'arresto da incasso, attacco 3/4", completo.

FDFU58951 05 109,00

Built-in stop cock, 3/4" connection, complete.

Robinet d'arrêt à encastrer, raccord 3/4", complet.

Absperventil Unterputz, Anschluss 3/4", komplett.

Llave de paso a empotrar, racor 3/4", completa.

20 N



FIRB02506

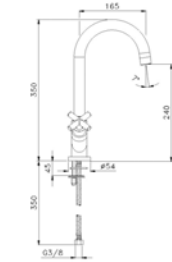

FIRB02516



Gruppo monoforo per lavello, con bocca girevole, areatore anticalcare M24x1, flex di alimentazione 3/8".

Single hole sink mixer, swivel spout, lime resistant areator M24x1, connecting flexible hose 3/8".

Mélangeur évier monotrou, bec mobile, aérateur anticalcaire M24x1, flex d'alimentation 3/8".

Spülen-Armatur, Schwenkauslauf, Anti-Kalk Perlator M24x1, flexibler Anschluss Schlauch 3/8".

Monoblock para fregadero, cuerpo giratorio, aireador anticalcáreo M24x1, conexiones de 3/8".

FGPU58926 05 221,00



FIRB02506

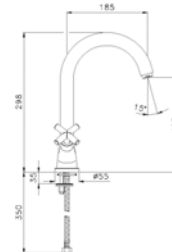

FIRB02516



Gruppo monoforo per lavello, con bocca girevole, areatore anticalcare M24x1, flex di alimentazione 3/8".

Single hole sink mixer, swivel spout, lime resistant areator M24x1, connecting flexible hose 3/8".

Mélangeur évier monotrou, bec mobile, aérateur anticalcaire M24x1, flex d'alimentation 3/8".

Spülen-Armatur, Schwenkauslauf, Anti-Kalk Perlator M24x1, flexibler Anschluss Schlauch 3/8".

Monoblock para fregadero, cuerpo giratorio, aireador anticalcáreo M24x1, conexiones de 3/8".

FGPU58927 05 240,00



FIRB02506

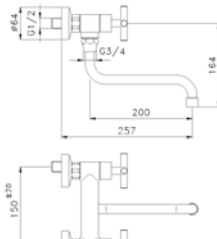

FIRB02516



Gruppo lavello a parete, con bocca girevole, areatore anticalcare M22x1.

Wall mounted sink mixer, swivel spout, lime resistant areator M22x1.

Mélangeur évier mural, bec mobile, aérateur anticalcaire M22x1.

Spülen-Wandarmatur, Schwenkauslauf, Anti-Kalk Perlator M22x1.

Grupo para fregadero a pared, cuerpo giratorio, aireador anticalcáreo M22x1.

FEPU58700 05 213,00

